

becker marine systems



BIMS – BECKER INTELLIGENT MONITORING SYSTEM BBMS – BECKER BEARING MONITORING SYSTEM

Usually, a ship's rudder is known as a passive part, not giving any feedback on its condition. Becker Marine Systems, well known for its superior rudder design and performance, invented two revolutionary rudder monitoring systems which enable the ship's crew for the first time to receive direct feedback from the rudder. In detail, Becker Marine Systems has enhanced its product portfolio by adding these two innovative systems:

- **BBMS** (Becker Bearing Monitoring System) for measurement of rudder neck bearing clearance
- **BIMS** (Becker Intelligent Monitoring System) for rudder force monitoring

Through different sensor systems installed on the rudder components Becker's new monitoring systems allow precise measurements instead of poor assumptions, for example about rudder neck wear. No more periodical diver inspections are necessary.

Furthermore, the monitoring systems allow continuous measurement of the rudder status and offer new and enriching possibilities for rudder service and manoeuvring improvement.

BIMS and BBMS are part of Industry 4.0. Operators will be able to optimise the efficiency and to minimise wear and tear.



BIMS – BECKER INTELLIGENT MONITORING SYSTEM

Until now modern navigation and positioning systems have been using rather general output signals for rudder control operation while manoeuvring, because the force generated at specific rudder angles is not available to the navigation system. This results in less efficient manoeuvring.

The Becker Intelligent Monitoring System (BIMS) is able to directly measure rudder forces and interface them with the ship's navigation systems as well as visualise rudder lift on the bridge. Thus improving manoeuvrability and allowing energy-saving autopilot operation and more efficient dynamic positioning.

- Determination of rudder lift, drag and torque
- Serial and network interfaces to navigation systems such as autopilot (AP) and dynamic positioning (DP) systems
- Fewer rudder motions during AP and DP operation
- Energy savings and emission reductions through improved efficiency
- Showing rudder force on the bridge and wings makes manoeuvring safer
- Reduced wear and costs of maintaining steering gear and rudder
- DNV GL Type Approval

BIMS is the technology for improving safety and performance by minimising stall conditions and rudder movements.

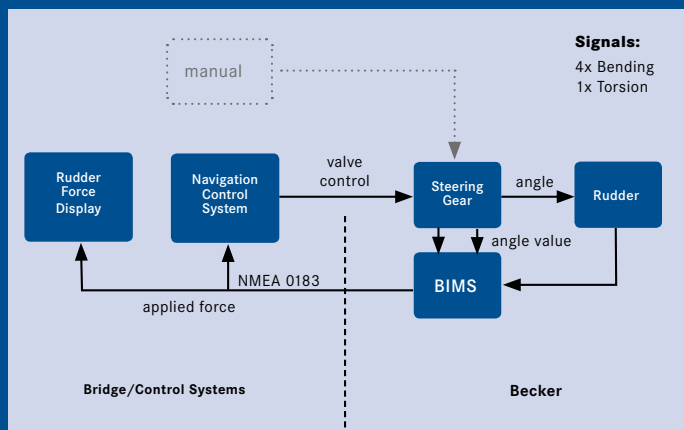

BIMS functional principle

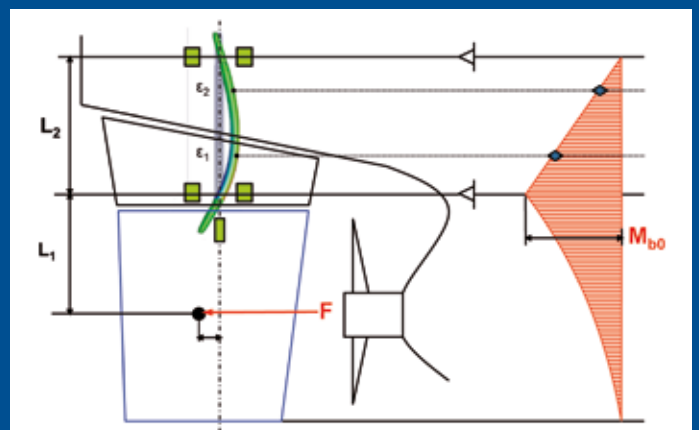

BIMS measurement of rudder force

BBMS – BECKER BEARING MONITORING SYSTEM

The Becker Bearing Monitoring System (BBMS) monitors wear on the rudder neck bearing by means of four wear sensors mounted in the neck bearing bush. Its sensors are worn out along with the bearing bush, thus enabling precise measurement of the neck bearing clearance to an accuracy of one millimetre. The neck bearing clearance measurement is transmitted to the processing unit (mounted in the steering gear room), which incorporates a panel to calibrate the system and display the values being monitored as well as the neck bearing wear history. Via the processing unit, the neck bearing clearances and measured values can be interfaced to any other monitoring and alarm system aboard the ship. Continuous monitoring of the neck bearing enables better planning of servicing activities and furthermore supersedes periodical neck bearing inspections performed by divers. The bearing wear history enables the lifetime of the neck bearing to be predicted in advance. As a result, the replacement of the bearing bush can be scheduled in line with the docking intervals of the ship to minimise service costs and efforts.

The monitoring systems sensors' robust and compact design withstand the harsh conditions inside the rudder structure and guarantee a long service life.

- Precise measurement of neck bearing wear
- Measurement accuracy of one millimetre
- Robust and compact sensor design for a long service life
- Neck bearing wear history
- Interface to alarm system available
- TFT touch panel
- Optimal planning of rudder service in line with docking intervals
- BBMS measurement supersedes diver inspections of neck bearing bush



BBMS sensor positions in neck bearing bush



Trunk equipped with BBMS



BIMS FOR SAFER MANOEUVRING

By displaying rudder force, the BIMS ensures optimal rudder performance for safe manoeuvring. It can detect low rudder forces, indicating where poor rudder response or even rudder stall can be expected. This enables the crew to take appropriate countermeasures in advance to achieve optimum rudder performance.



BIMS FOR ENERGY-SAVING AUTOPILOT OPERATION

Travelling on autopilot, the rudder of a ship operates continuously within a range of several degrees, leading to a significant increase in resistance and fuel consumption. Direct force feedback made available by BIMS supports the ship's autopilot and navigation system to sail with fewer rudder movements, resulting in energy savings with a corresponding reduction in emissions.



BIMS FOR EFFICIENT DYNAMIC POSITIONING

BIMS provides the perfect solution to support and improve the DP system using conventional rudder-propeller arrangements. Precise measurement of rudder force leads to better station-keeping performance as the DP model is better updated, resulting in more reliable dynamic positioning operations. Additionally, the energy savings resulting from fewer rudder movements in DP mode are substantial.



BBMS FOR OPTIMISED RUDDER SERVICE

Continuous measurement of the neck bearing clearance by BBMS enables a precise prediction as to when the neck bearing bush will be worn off. Such information is vital to schedule and coordinate the neck bearing replacement in advance and in line with the docking intervals of the ship. This optimises the timing of rudder service activities thus minimising maintenance costs and assuring operational safety.

right: exemplary case >>

